

Ready to Meet Tomorrow's Power  
Generation Requirements Today

# AP1000™

Simple

Safe

Innovative



Westinghouse

You can be sure ...  
if it's Westinghouse



# Nuclear Power

## - The Environmentally Clean Option

As the world's population rises, so does its reliance on electricity. Likewise, energy demands are soaring as new technologies and expanded development create additional energy needs. This trend will only continue as nations grow and developing countries emerge.

For the most part, fossil fuels have powered whole nations and economies. But as fossil fuels dwindle and as the effects of pollution and global warming increase, it's time to look for better solutions to the world's energy needs.

Continued reliance on fossil fuels for the vast majority of our energy needs is simply not realistic. Viewing the situation in a worldwide context magnifies the problem. With an additional two billion people expected to need energy by 2020, fossil fuels cannot adequately satisfy the demand without further harming the environment. Likewise, renewable energy sources are still in their infancy, as well as being an unrealistic means to provide baseload generation.

It's time to realize a generation of power that is safe, plentiful, economical and clean. It's time for a new generation of nuclear power.



# AP1000™

**The Nuclear Renaissance Starts Here.™**

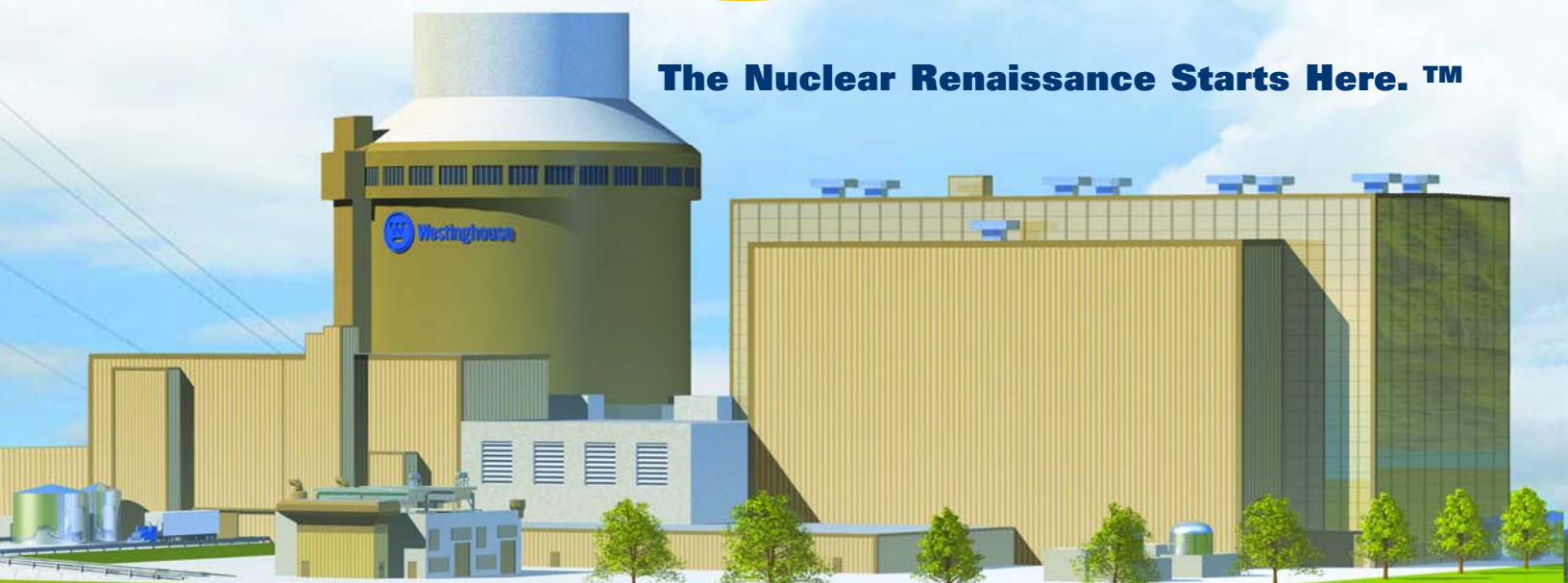



AP1000



*Featuring proven technology and innovative passive safety systems, the Westinghouse AP1000™ pressurized water reactor can achieve competitive generation costs in the current electricity market without emitting greenhouse gases and further harming the environment.*

Westinghouse Electric Company, the pioneer in nuclear energy, once again sets a new industry standard with the AP1000. The AP1000 is the safest and most economical nuclear power plant available in the worldwide commercial marketplace, and is the only Generation III+ reactor to receive Design Certification from the U.S. Nuclear Regulatory Commission (NRC).

The established design of the AP1000 offers three distinct advantages over other designs:

-  Unequaled safety
-  Economic competitiveness
-  Improved and more efficient operations

Based on nearly 20 years of research and development, the AP1000 builds and improves upon the established technology of major components used in current Westinghouse-designed plants. Components such as steam generators, digital instrumentation and controls, fuel, pressurizers, and reactor vessels are currently in use around the world and have years of proven, reliable operating experience.

Historically, Westinghouse plant designs and technology have forged the cutting edge of nuclear plant technology around the world. Today, nearly 50 percent of the world's 440 nuclear plants are based on Westinghouse technology. Westinghouse continues to be the nuclear industry's global leader.

*(Generation III+ is the Department of Energy's nomenclature for Generation III Advanced Light Water Reactors with improved economics and safety.)*

*AP1000 is a trademark of Westinghouse Electric Company LLC*



**You can be sure...  
if it's Westinghouse**

# AP1000™ at a Glance

The AP1000™ is a two-loop pressurized water reactor (PWR) that uses a simplified, innovative and effective approach to safety. With a gross power rating of 3,415 megawatt thermal (MWt) and a nominal net electrical output of 1,117 megawatt electric (MWe), the AP1000, with a 157-fuel-assembly core, is ideal for new baseload generation. The standardized reactor design complies with the Advanced Light Water Reactor Utility Requirements Document (URD).

The AP1000 received Final Design Approval from the U.S. NRC in September 2004, and Design Certification in December 2005. The AP1000 is the first and only Generation III+ reactor to receive such certification from the NRC. Additionally the European Utility Requirements (EUR) organization certified that the AP1000 pressurized water reactor has successfully passed all the steps of analysis for compliance with European Utility Requirements, confirming that the AP1000 can be successfully deployed in Europe.



## Simplified Plant Design

Simplification was a major design objective of the AP1000. Simplifications in overall safety systems, normal operating systems, the control room, construction techniques, and instrumentation and control systems provide a plant that is easier and less expensive to build, operate, and maintain. Plant simplifications yield fewer components, cable, and seismic building volume, all of which contribute to considerable savings in capital investment, and lower operation and maintenance costs. At the same time, the safety margins for AP1000 have been increased dramatically over currently operating plants.



## The Technology

The AP1000 is comprised of components that incorporate many design improvements distilled from 50 years of successful operating nuclear power plant experience. The reactor vessel and internals, steam generator, fuel, and pressurizer designs are improved versions of those found in currently operating Westinghouse-designed PWRs. The reactor coolant pumps are canned-motor pumps, the type used in many other industrial applications where reliability and long life are paramount requirements.

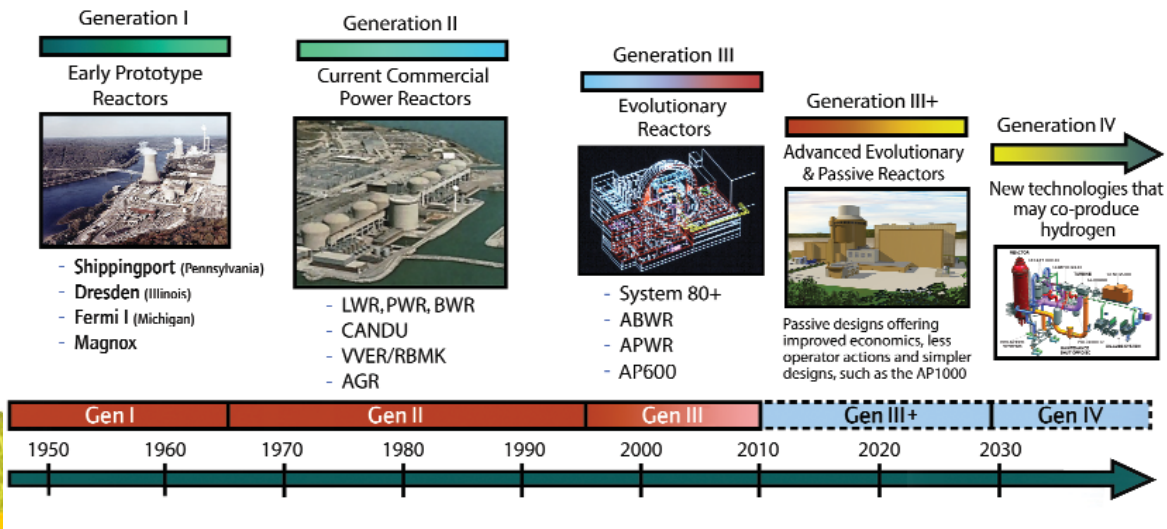

## Licensed Passive Safety Systems

The unique feature of the AP1000 is its use of natural forces - natural circulation, gravity, convection and compressed gas - to operate in the highly unlikely event of an accident, rather than relying on operator actions and ac power. Even with no operator action and a complete loss of all on-site and off-site ac power, the AP1000 will safely shut down and remain cool.

Because natural forces are well understood and have worked as intended in large-scale testing, no demonstration plant is required. The Westinghouse advanced passive reactor design underwent the most thorough pre-construction licensing review ever conducted by the U.S. NRC.

## Large Safety Margins

The AP1000 meets the U.S. NRC deterministic-safety and probabilistic-risk criteria with large margins. The safety analysis is documented in the AP1000 Design Control Document (DCD) and Probabilistic Risk Assessment (PRA). Results of the PRA show a very low core damage frequency (CDF) that is 1/100 of the CDF of currently operating plants and 1/20 of the CDF deemed acceptable in the Utility Requirements Document for new, advanced reactor designs. It follows that the AP1000 also improves upon the probability of large release goals for advanced reactor designs in the event of a severe accident scenario to retain the molten core within the reactor vessel.

## Ready for Implementation

Having received Design Certification, the AP1000 has the highest degree of design completion of any Generation III+ plant design. Demonstrating confidence in the AP1000 plant design and its readiness for implementation, several U.S. utilities have selected the AP1000 design in their applications to the U.S. NRC for combined construction and operating licenses (COL). Additionally, China is building four AP1000s with the first unit scheduled to be online by 2013.

| Plant Simplifications Yield Fewer Components, Cable and Building Volume |                          |        |
|---|--------------------------|--------|
| Component   | 1000 MWe Reference Plant | AP1000 |
| Pumps   | 280                      | 180    |
| Safety class valves   | 2,800                    | 1,400  |
| Safety class piping, ft   | 110,000                  | 19,000 |
| Cable, million ft   | 9.1                      | 1.2    |
| Seismic building volume, million ft <sup>3</sup>                        | 12.7                     | 5.6    |

| Operational Technology Incorporated into the AP1000 |  |
|---|--|
| Component   | Prior Use of Technology  |
| Reactor vessel and internals                        | Doel 4, Tihange 3  |
| CRDMs   | Westinghouse plants worldwide  |
| Fuel  | South Texas 1&2, Doel 4, Tihange 3   |
| Large Model F steam generators                      | Similar designs at ANO-2, San Onofre, Waterford, Palo Verde                    |
| Canned motor reactor coolant pumps                  | Fossil boilers and other industrial applications (inverted canned motor pumps) |
| Pressurizer   | 70 Westinghouse plants worldwide   |



# Unequaled Safety

*The AP1000™ pressurized water reactor is based on a simple concept: in the event of a design-basis accident, such as a main coolant-pipe break, the plant is designed to achieve and maintain safe shutdown condition without operator action, and without the need for ac power or pumps. Rather than relying on active components, such as diesel generators and pumps, the AP1000 relies on natural forces - gravity, natural circulation, and compressed gases - to keep the core and the containment from overheating.*

The AP1000 provides multiple levels of defense for accident mitigation (defense-in-depth), resulting in extremely low core-damage probabilities while minimizing the occurrences of containment flooding, pressurization, and heat-up. Defense-in-depth is integral to the AP1000 design, with a multitude of individual plant features including the selection of appropriate materials; quality assurance during design and construction; well-trained operators; and an advanced control system and plant design that provide substantial margins for plant operation before approaching safety limits. In addition to these protections, the following features contribute to defense-in-depth of the AP1000:

- **Non-safety Systems.** The non safety-related systems respond to the day-to-day plant transients, or fluctuations in plant conditions. For events that could lead to overheating of the core, these highly reliable non-safety systems actuate automatically to provide a first level of defense to reduce the likelihood of unnecessary actuation and operation of the safety-related systems.
- **Passive Safety-Related Systems.** The AP1000 safety-related passive systems and equipment are sufficient to automatically establish and maintain core cooling and containment integrity indefinitely following design-basis events, assuming the most limiting single failure, with no operator action, and no on-site or off-site ac power sources. An additional level of defense is provided through diverse mitigation functions that are included within the passive safety-related systems.
- **In-vessel Retention of Core Damage.** The AP1000 is designed to drain the high capacity in-containment refueling water storage tank (IRWST) water into the reactor cavity in the event that the core has overheated. This provides cooling on the outside of the reactor vessel preventing reactor vessel failure and subsequent spilling of molten core debris into the containment. Retention of debris in the vessel significantly reduces uncertainty in the assessment of containment failure and radioactive release to the environment due to ex-vessel severe accident phenomena such as the interaction of molten core material with concrete.
- **Fission Product Release.** Fuel cladding provides the first barrier to the release of radiation in the highly unlikely event of an accident. The reactor coolant pressure boundary, in particular the reactor pressure vessel and the reactor coolant piping, provide independent barriers to prevent the release of radiation. Furthermore, in conjunction with the surrounding shield building, the steel containment vessel provides additional protection by establishing a third barrier and by providing natural convection air currents to cool the steel containment. The natural convection cooling can be enhanced with evaporative cooling by allowing water to drain from a large tank located at the top of the shield building on to the steel containment.

## AP1000 exceeds safety goals

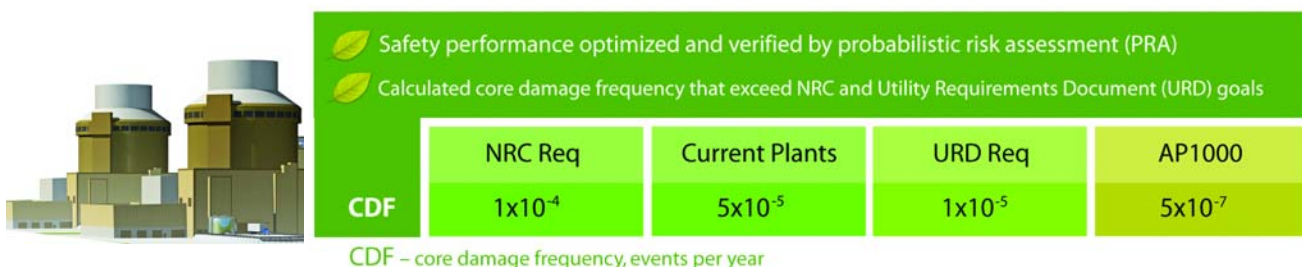

# Non Safety-related Active Systems for Defense-in-Depth

Many of the active safety-related systems in existing and evolutionary PWR designs are retained in the AP1000 but are designated as non safety-related.

The AP1000 active non safety-related systems support normal operation and are also the first line of defense in the event of transients or plant upsets. Although these systems are not credited in the safety analysis evaluation, they provide additional defense-in-depth by adding a layer of redundancy and diversity. In addition to contributing to the very low core damage frequency (CDF), the non safety-related, active systems require fewer in-service inspections, less testing and maintenance, and are not included in the simplified technical specifications. For defense-in-depth, most planned maintenance for these non-safety systems can be performed while the plant is operating.

Examples of non safety-related systems that provide defense-in-depth capabilities for the AP1000 design include the chemical and volume control system, normal residual heat removal system, and the startup (auxillary) feedwater system. These systems utilize non-safety support systems such as the standby diesel generators, the component-cooling water system, and the service water system. The AP1000 also includes other active non safety-related systems, such as the heating, ventilation and air-conditioning (HVAC) systems, which remove heat from the instrumentation and control (I&C) cabinet rooms and the main control room. These are, in simpler form in the AP1000, familiar systems that are used in current PWRs as safety systems. In the AP1000, these HVAC systems are a simplified non-safety first line of defense, which are backed up by the ultimate defense, the passive safety-grade systems.

This defense-in-depth class of systems includes the containment hydrogen control system, which consists of the hydrogen monitoring system, passive autocatalytic hydrogen recombiners, and hydrogen igniters (powered by batteries).

## Probabilistic Risk Assessment (PRA)

From a letter dated July 20, 2004, from the Chairman of the Advisory Committee on Reactor Safeguards to the Chairman of the U.S. NRC on its Reactor Safeguards Report about the safety aspects of the Westinghouse Electric Company Application for Certification of the AP1000 Passive Plant Design:

"The AP1000 Design Certification application included a PRA in accordance with regulatory requirements. This PRA was done well and rigorous methods were used. We found that this PRA was acceptable for certification purposes. The mean estimates of the risk metrics are:

|                               |                             |
|-------------------------------|-----------------------------|
| CDF (Core Damage Frequency)   | $5 \times 10^{-7}$ per year |
| LRF (Large Release Frequency) | $6 \times 10^{-9}$ per year |

"These risk metrics are well within the agency's expectations for advanced plants. The fact that the PRA was an integral part of the design process was significant to achieving this estimated low risk."



# Passive Safety Systems

*A major safety advantage of passive plants versus current or evolutionary light water reactors (LWRs) is that long-term accident mitigation is maintained without operator action or reliance on off-site or on-site ac power.*

*The AP1000 uses extensively analyzed and tested passive safety systems to improve the safety of the plant. The Advisory Council on Reactor Safeguards (ACRS) and the U.S. NRC have scrutinized these systems and ruled that they meet the U.S. NRC single-failure criteria, and other safety criteria such as Three Mile Island lessons learned, and generic safety issues.*

The AP1000 passive safety systems require no operator actions to mitigate design-basis accidents. These systems use only natural forces such as gravity, natural circulation and compressed gas to achieve their safety function. No pumps, fans, diesels, chillers or other active machinery are used, except for a few simple valves that automatically align and actuate the passive safety systems. To provide high reliability, these valves are designed to move to their safeguard positions upon loss of power or upon receipt of a safeguards actuation signal- a single move powered by multiple, reliable Class 1E dc power batteries. The passive safety systems do not require the large network of active safety support systems (ac power, diesels, HVAC, pumped cooling water) that are needed in typical nuclear plants. As a result, in the case of the AP1000, those active support systems no longer must be safety class, and they are either simplified or eliminated. With less safety-grade equipment, the seismic Category 1 building volumes needed to house safety-grade equipment are greatly reduced. In fact, most of the safety equipment can now be located within containment, resulting in fewer containment penetrations.

The AP1000 passive safety systems include:

- Passive core cooling system (PXS)
- Containment isolation
- Passive containment cooling system (PCS)
- Main control room emergency habitability system



## Passive Core Cooling System

The AP1000 passive core cooling system (PXS) performs two major functions:

- Safety injection and reactor coolant makeup from the following sources:
  - Core makeup tanks (CMTs)
  - Accumulators
  - In-containment refueling water storage tank (IRWST)
  - In-containment passive long-term recirculation
- Passive residual heat removal (PRHR) utilizing:
  - Passive residual heat removal heat exchanger (PRHR HX)
  - IRWST

Safety injection sources are connected directly to two nozzles dedicated for this purpose on the reactor vessel. These connections, which have been used before on two-loop plants, reduce the possibility of spilling part of the injection flow in a large break loss-of-coolant accident.

### *High Pressure Safety Injection with CMTs*

Core makeup tanks (CMTs) are called upon following transients where the normal makeup system is inadequate or is unavailable. Two core makeup tanks (CMTs) filled with borated water in two parallel



trains are designed to function at any reactor coolant system (RCS) pressure using only gravity, and the temperature and height differences from the reactor coolant system cold leg as the motivating forces. These tanks are designed for full RCS pressure and are located above the RCS loop piping. If the water level or pressure in the pressurizer reaches a set low level, the reactor, as well as the reactor coolant pumps, are tripped and the CMT discharge isolation valves open automatically. The water from the CMTs recirculates then flows by gravity through the reactor vessel.

### *Medium Pressure Safety Injection with Accumulators*

As with current pressurized water reactors, accumulators are required for large loss-of-coolant accidents (LOCAs) to meet the immediate need for higher initial makeup flows to refill the reactor vessel lower plenum and downcomer following RCS blowdown. The accumulators are pressurized to 700 psig with nitrogen gas. The pressure differential between the pressurized accumulators and the dropping RCS pressure ultimately forces open check valves that normally isolate the accumulators from the RCS. Two accumulators in two parallel trains are sized to respond to the complete severance of the largest RCS pipe by rapidly refilling the vessel downcomer and lower plenum. The accumulators continue delivery to supplement the CMTs in maintaining water coverage of the core.

### *Low Pressure Reactor Coolant Makeup from the IRWST*

Long-term injection water is supplied by gravity from the large IRWST, which is located inside the containment at a height above the RCS loops. This tank is at atmospheric pressure and, as a result, the RCS must be depressurized before injection can occur. The AP1000 automatically controls depressurization of the RCS to reduce its pressure to near atmospheric pressure, at which point the gravity head in the IRWST is sufficient to overcome the small RCS pressure and the pressure loss in the injection lines to provide IRWST water to the reactor.

### *Passive Residual Heat Removal*

The AP1000 has a passive residual heat removal (PRHR) subsystem that protects the plant against transients that upset the normal heat removal from the primary system by the steam generator feedwater and steam systems. The passive RHR subsystem satisfies the U.S. NRC safety criteria for loss of feedwater, feedwater-line breaks, and steam-line breaks with a single failure.

The system includes the passive RHR heat exchanger consisting of a 100-percent capacity bank of tubes located within the IRWST. This heat exchanger is connected to the reactor coolant system in a natural circulation loop. The loop is isolated from the RCS by valves that are normally closed, but will open if power is lost or upon other signals from the instrumentation and control protection system. The difference in temperature and the elevation difference between the hot inlet water and the cold outlet water of the heat exchanger drives the natural circulation loop. If the reactor coolant pumps are running, the passive RHR heat exchange flow will be increased.

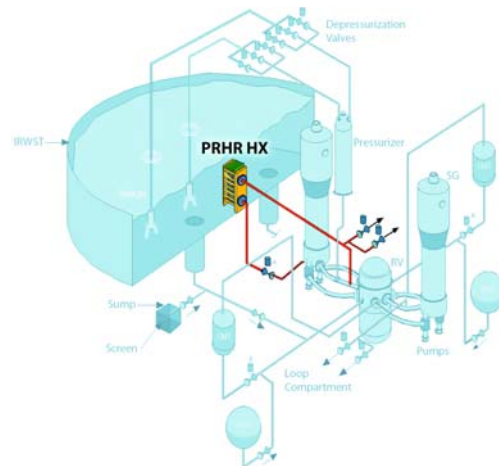

The IRWST is the heat sink for the passive RHR heat exchanger. The IRWST water volume is sufficient to absorb decay heat for about two hours before the water starts to boil. After that, the steam from the boiling IRWST condenses on the steel containment vessel walls and then drains back into the IRWST by specially designed gutters.

## Automatic Depressurization System

The automatic depressurization system (ADS) depressurizes the reactor coolant system (RCS) and enables lower pressure safety injection water to enter the reactor vessel and the core. It is activated by a level set-point in the core makeup tank (CMT). The ADS is comprised of three stages of motor-operated valves (MOVs) located above the pressurizer, and a fourth stage connected to the RCS hot legs and controlled by a squib valve, which opens by the actuation of an explosive charge. The first three stages of MOVs are arranged in six parallel sets (two normally closed valves in series). These MOV valves are activated on two-out-of-four actuation signals. The fourth stage of this system consists of four large valves, in two pairs, that open off the hot legs, reducing the pressure to atmospheric, allowing gravity injection from the IRWST. This eventually evolves into a long-term cooling mode with containment sump recirculation. The ADS valves are arranged to open in a prescribed sequence determined by the core makeup tank (CMT) level and a sequence timer.

The automatic RCS depressurization feature meets the following criteria:

- The reliability (redundancy and diversity) of the ADS valves and controls satisfies the single-failure criterion as well as the failure tolerance called for by the low core-damage frequency goals.
- The design provides for both real demands (i.e., RCS leaks and failure of the CVS makeup pumps) and spurious instrumentation signals. The probability of significant flooding of the containment due to the use of the ADS is less than once in 600 years. The design is such that for small-break loss-of-coolant accident (LOCA) up to eight inches (20.32 cm) in diameter, the core remains covered.

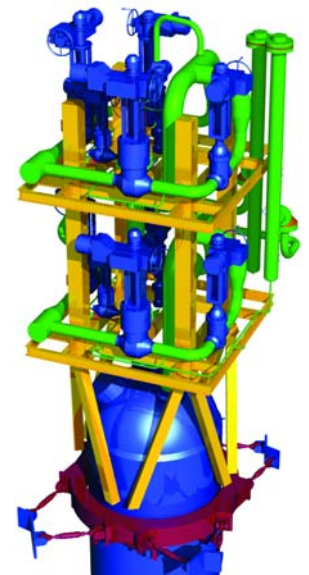
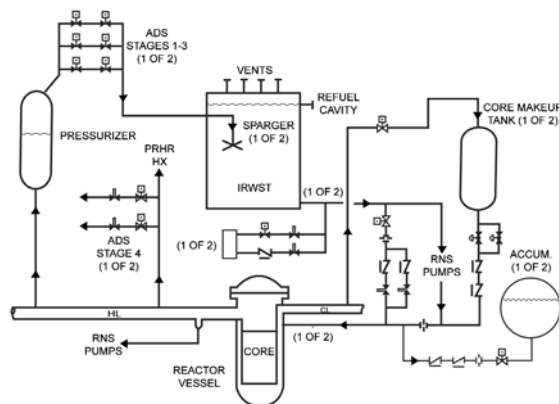

| Increased Safety Margins   |   |                               |
|--|---|-------------------------------|
| Design Basis Accident  | Typical Plant                           | AP1000                        |
| Loss Flow Margin to DNBR Limit                                     | ~ 10-14%                                | ~ 16 %                        |
| Feedline Break, Subcooled Margin                                   | > 0°F                                   | ~ 140°F                       |
| Steam generator tube rupture                                       | Operator actions required in 10 minutes | Operator actions not required |
| Small loss-of-coolant accident (LOCA)                              | 3" LOCA, core uncovers, PCT <1500°F     | <8" LOCA, No core uncover     |
| Large LOCA peak clad temperature with uncertainty                  | 1700-2000°F *                           | <1600°F *                     |
| Anticipated transient without reactor trip, pressure (% core life) | 3200 psig (90%)                         | 2800 psig (100%)              |

\* Based on ASTRUM analysis. AP1000 was licensed with a very conservative "bounding" best-estimate large break LOCA analysis

## Containment Isolation

Containment isolation is provided to prevent or limit the escape of fission products that may result from postulated accidents. In the event of an accident, the containment isolation provisions are designed so that fluid lines penetrating the containment boundary are isolated. The containment isolation system consists of the piping, valves and actuators that isolate the containment.

Containment isolation is improved in the AP1000 because:

- The number of normally open penetrations is reduced by 50 percent, thanks to the simpler passive safety systems
- Penetrations that are normally open and at risk are fail safe - they fail in the closed position
- There is no recirculation of irradiated water outside of containment for design-basis accidents
- The steel containment is a high integrity steel pressure vessel, rather than a concrete vessel

The function of the AP1000 passive containment cooling system (PCS) is to prevent the containment vessel from overheating and exceeding the design pressure, which could result in a breach of the containment and the loss of the final barrier to radioactive release.

## Passive Containment Cooling System (PCS)

The PCS consists of the following components:

- Air inlet and exhaust paths that are incorporated in the shield building structure
- An air baffle that is located between the steel containment vessel and the concrete shield building
- A passive containment cooling water storage tank that is incorporated in the shield building structure above the containment
- A water distribution system
- An ancillary water storage tank and two recirculation pumps for onsite storage of additional PCS cooling water, heating to avoid freezing, and for maintaining proper water chemistry

### Natural Circulation

The PCS is able to effectively cool the containment following an accident such that the design pressure is not exceeded and the pressure is rapidly reduced. The steel containment vessel itself provides the heat transfer surface that allows heat to be removed from inside the containment and rejected to the atmosphere. Heat is removed from the containment vessel by a natural circulation flow of air through the annulus formed by the outer shield building and the steel containment vessel it houses. Outside air is pulled in through openings near the top of the shield building and pulled down, around the baffle and then flows upward out of the shield building.

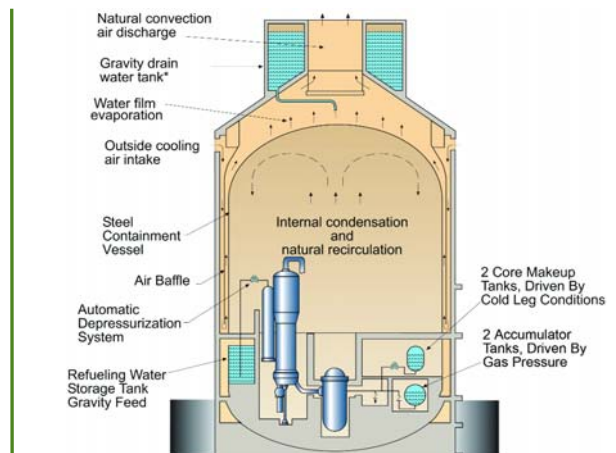

The flow of air is driven by the chimney effect of air heated by the containment vessel rising and finally exhausting up through the central opening in the shield building roof.



## Water Evaporation

If needed, the air cooling can be supplemented by water evaporation on the outside of the containment shell. The water is drained by gravity from a tank located on top of the containment shield building. Three normally closed, fail-open valves will open automatically to initiate the water flow if a high containment-pressure threshold is reached. The water flows from the top, outside, domed surface of the steel containment shell and down the side walls allowing heat to be transferred and removed from the containment by evaporation. The water tank has sufficient capacity for three days of operation, after which time the tank could be refilled, most likely from the ancillary water storage tank. If the water is not replenished after three days, the containment pressure will increase, but the peak pressure is calculated to reach only 90 percent of design pressure. After three days, air cooling alone is sufficient to remove decay heat.

## In-Vessel Retention of Core Damage

The AP1000 is designed to mitigate a postulated severe accident such as core melt. In this event, the AP1000 operator can act to flood the reactor cavity- the space immediately surrounding the reactor vessel - with water from the in-containment refueling water storage tank (IRWST), submerging the lower portion of the reactor vessel. An insulating structure that surrounds the reactor vessel provides the pathway for water cooling to reach the vessel; flow around the bottom vessel head and up the vessel-insulation wall annulus; and to vent resulting steam from cooling the vessel from the reactor cavity. The cooling is sufficient to prevent molten core debris in the lower head from melting the steel vessel wall and spilling into the containment. Retaining the debris in the reactor vessel protects the containment integrity by simply avoiding the uncertainties associated with ex-vessel severe accident phenomena, such as ex-vessel steam explosion and core-concrete interaction with the molten core material.

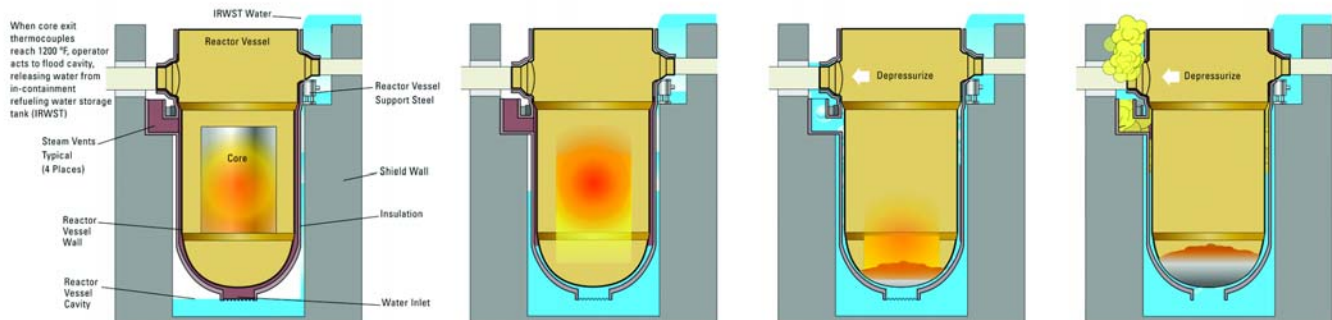

## Main Control Room Emergency Habitability System

The main control room can be isolated in case of high airborne radiation levels. The main control room (MCR) emergency habitability system is comprised of a set of compressed air tanks connected to a main and an alternate air delivery line. Components common to both lines include a manual isolation valve, a pressure-regulating valve, and a flow metering orifice. This system is designed to provide the ventilation and pressurization needed to maintain a habitable environment for up to 11 people in the MCR for 72 hours following any design-basis accident.

# Economic Competitiveness

*Construction costs of commercial nuclear generating plants must be reduced in order to expand the future use of nuclear energy. Two of the drivers of plant construction costs are the cost of financing during the construction phase and the substantial amount of skilled-craft-labor hours needed on site during construction. The AP1000™ pressurized water reactor's extensive use of modularization of plant construction mitigates both of these drivers.*

## Overnight Construction Cost

From the outset, the AP1000 was designed to reduce capital costs and to be economically competitive with contemporary fossil-fueled plants. This requires lower overnight construction costs and higher confidence in the construction schedule.

The AP1000 reduces the amount of safety-grade equipment required by using passive safety systems. Consequently, less Seismic Category I building volume is required to house the safety equipment (approximately 45 percent less than a typical reactor). The AP1000's modular construction design further reduces the construction schedule and the construction risks, with work shifted to factories with their better quality and cost control as well as labor costs that are less than those at the construction site. This also allows more work to be done in parallel. The use of heavy lift cranes enables an "open top" construction approach, which is effective in reducing construction time.

With new computer-modeling capabilities, Westinghouse is able to optimize and choreograph the construction plan of an AP1000 in advance by simulation. The result is a very high confidence in the construction schedule.



### AP1000 simplified plant arrangement:

Much smaller seismic building volumes than current or evolutionary plants cut construction costs

Major construction improvement by using large factory-made structural modules assembled and lifted into place with heavy duty cranes at site

Large laydown areas in containment for ease of work and shortened outages

## Simplified Plant Arrangement

The AP1000 has a smaller footprint than an existing nuclear power plant with the same generating capacity. The plant arrangement provides separation between safety-related and non safety-related systems to preclude adverse interaction between safety-related and non safety-related equipment.

Separation between redundant, safety-related equipment trains and systems provides confidence that the safety design functions of the AP1000 can be performed. In general, this separation is achieved by partitioning an area with concrete walls.

The AP1000 plant is arranged with the following principal building structures, each on its own base mat:

- Nuclear Island (the only Seismic Category 1 structure)
- Turbine Building
- Annex Building
- Diesel Generator Building
- Radwaste Building



## *Nuclear Island*

The nuclear island is designed to meet Seismic Category I structural requirements. The volume of this building is much smaller than the buildings in previous nuclear power plant designs. This provides a large capital cost savings as seismic structures cost roughly three times as much as non-seismic structures. The nuclear island consists of the steel containment vessel, the concrete shield building and the auxiliary building. The nuclear island is designed to withstand the effects of postulated internal events such as fires and flooding without loss of capability to perform safety functions.

The **containment vessel** is a high integrity, freestanding steel structure with a wall thickness of 1.75 inches (4.44 cm). The containment is 130 feet (39.6 m) in diameter. The ring sections and vessel heads are constructed of steel plates pre-formed in an off-site fabrication facility and shipped to the site for assembly and installation using a large-capacity crane.

The primary containment prevents the uncontrolled release of radioactivity to the environment. It has a design leakage rate of 0.10 weight percent per day of the containment air during a design-basis accident and the resulting containment isolation.

The AP1000 containment contains a 16-foot (4.9m) diameter main equipment hatch and a personnel airlock at the operating-deck level, and a 16-foot (4.9m) diameter maintenance hatch and a personnel airlock at grade level. These large hatches significantly improve accessibility to the containment during outages and, consequently, reduce the potential for congestion at the containment entrances. These containment hatches, located at the two different levels, allow activities occurring above the operating deck to be unaffected by activities occurring below the operating deck.

The containment arrangement provides significantly larger laydown areas than most conventional plants at both the operating deck level and the maintenance floor level. Ample laydown space is provided for staging of equipment and personnel, equipment removal paths, and space to accommodate remotely operated service equipment and mobile units. Access platforms and lifting devices are provided at key locations, as are service provisions such as electrical power, demineralized water, breathing and service air, ventilation and lighting.

**Concrete Shield Building** -- The AP1000 containment design incorporates a shield building that surrounds the containment vessel and forms the natural convection annulus for containment cooling. This building is a cylindrical, reinforced concrete structure with a conical roof that supports the water storage tank and air diffuser (or chimney) of the passive containment cooling system (PCS). It shares a common base mat with the primary containment and auxiliary building, and is designed as a seismic Category 1 structure. It has an inner diameter of about 140 feet (43m), a height of 73.25 ft (22 m), and a wall thickness of 3 ft (0.9 m) in the cylindrical section.

The two primary functions of the shield building during normal operation are 1) to provide an additional radiological barrier for radioactive systems and components inside the containment vessel and 2) to protect the containment vessel from external events, such as tornados and tornado-driven objects that might impinge on it. As described earlier, under design-basis accident conditions, the shield building serves as a key component of the PCS by aiding in the natural convective cooling of the containment.

**Auxiliary Building** -- The auxiliary building is designed to provide protection and separation for the Seismic Category 1 mechanical and electrical equipment located outside the containment building. The building also provides protection for safety-related equipment against the consequences of internal and external events. Specifically, the auxiliary building houses the main control room, Class 1E I&C systems, Class 1E electrical systems, fuel handling and spent-fuel handling area, mechanical equipment areas, liquid and gas radwaste areas, containment penetration areas, and main steam and feedwater isolation valve compartments. Large staging and laydown areas are provided outside the two equipment hatches.

## Non-seismic Buildings

The following buildings are non-seismic Category 1 structures, and contain no safety-related equipment. They are designed for wind and seismic loads in accordance with the Uniform Building Code. The foundation of each building is a reinforced concrete mat on grade.

- The **annex building** serves as the main personnel entrance to the power generation complex. The building includes the health physics area, the non-Class 1E ac and dc electric power systems, the ancillary diesel generators and their fuel supply, other electrical equipment, the technical support center, and various HVAC systems. The annex building provides large staging and laydown areas immediately outside the equipment hatches.
- The **turbine building** houses the main turbine, generator, and associated fluid and electrical systems. It also houses the makeup water purification system.
- The **diesel generator building** houses two diesel generators and their associated HVAC equipment.
- The **radwaste building** contains facilities for segregated storage of various categories of solid waste prior to processing, for processing by mobile systems, and for storing processed solid waste in shipping and disposal containers.

## Comparison of Important Nuclear Island Buildings

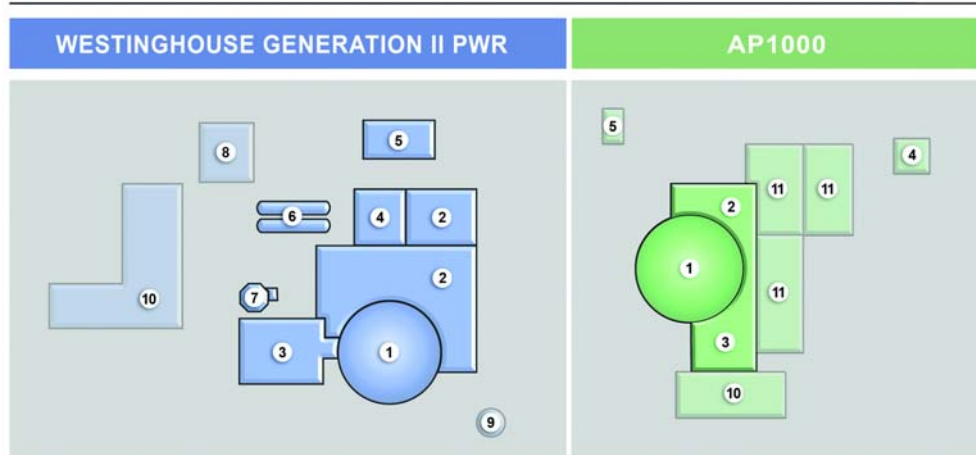

Darker areas shown are Seismic I category buildings



- |                               |  |
|-------------------------------|--|
| 1. Shield / Containment       | 7. Refueling Water Storage Tank        |
| 2. Auxiliary Building         | 8. Demineralizer / Potable Water Plant |
| 3. Fuel Area                  | 9. Condensate Storage Tank             |
| 4. Diesel Generators          | 10. Radwaste Building                  |
| 5. Service Water Pumphouse    | 11. Annex Building                     |
| 6. Emergency Fuel Oil Storage |  |

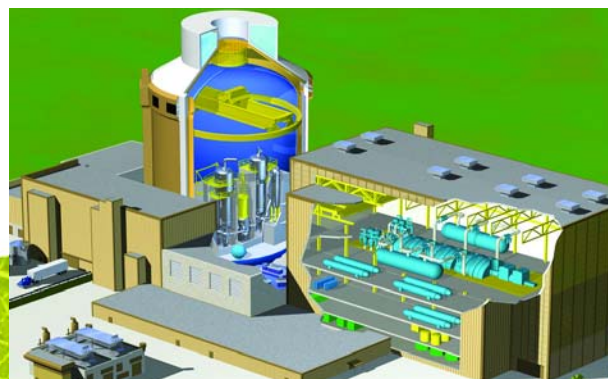

# Modularization and Construction

Structural, piping and equipment modules provide:

- Shortened construction schedule
- Reduced field manpower
- Increased factory-based manufacturing and assembly of modules
- Improved quality - pre-testing and inspection of modules prior to shipment
- Reduced site congestion

## Modular by Design

The AP1000 has been designed to make use of modern, modular-construction techniques. The design incorporates vendor-designed skids and equipment packages, as well as large, multi-ton structural modules and special-equipment modules. Modularization allows construction tasks that were traditionally performed in sequence to be completed in parallel. Factory-built modules can be installed at the site in a planned construction schedule of three years - from first concrete pour to fuel load. This duration has been verified by experienced construction managers through 4D (3D models plus time) reviews of the computer-simulated construction sequence.

| Typical Breakdown of AP1000 Modules |                    |                |                              |       |
|-------------------------------------|--------------------|----------------|------------------------------|-------|
|                                     | Structural Modules | Piping Modules | Mechanical Equipment Modules | Total |
| Containment                         | 41                 | 20             | 12                           | 73    |
| Auxiliary Building                  | 42                 | 34             | 29                           | 105   |
| Turbine Building                    | 29                 | 45             | 14                           | 88    |
| Annex Building                      | 10                 |                |                              | 10    |
| Total                               | 122                | 99             | 55                           | 276   |

## Parallel Work Processes in Controlled Environments

AP1000 modularization allows many more construction activities to proceed in parallel. This reduces the calendar time for plant construction, thereby reducing the cost of money and the exposure risks associated with plant financing. Furthermore, the reduced amount of work on site means the amount of skilled field-craft labor, which is more costly than shop labor, is greatly reduced. In addition to the labor cost savings, more of the welding and fabrication performed in a factory environment increases the quality of the work, improves the flexibility in scheduling, and reduces the amount of specialized tools on site.

To achieve proper interfaces with the rest of the plant systems and structures, interconnected piping between modules is represented in the 3D design model. This eliminates the interference concerns of typical field-run commodities (e.g., piping, duct, raceway) and "stick-built" construction techniques.



## Modularization Used to Reduce AP1000 Construction Cost

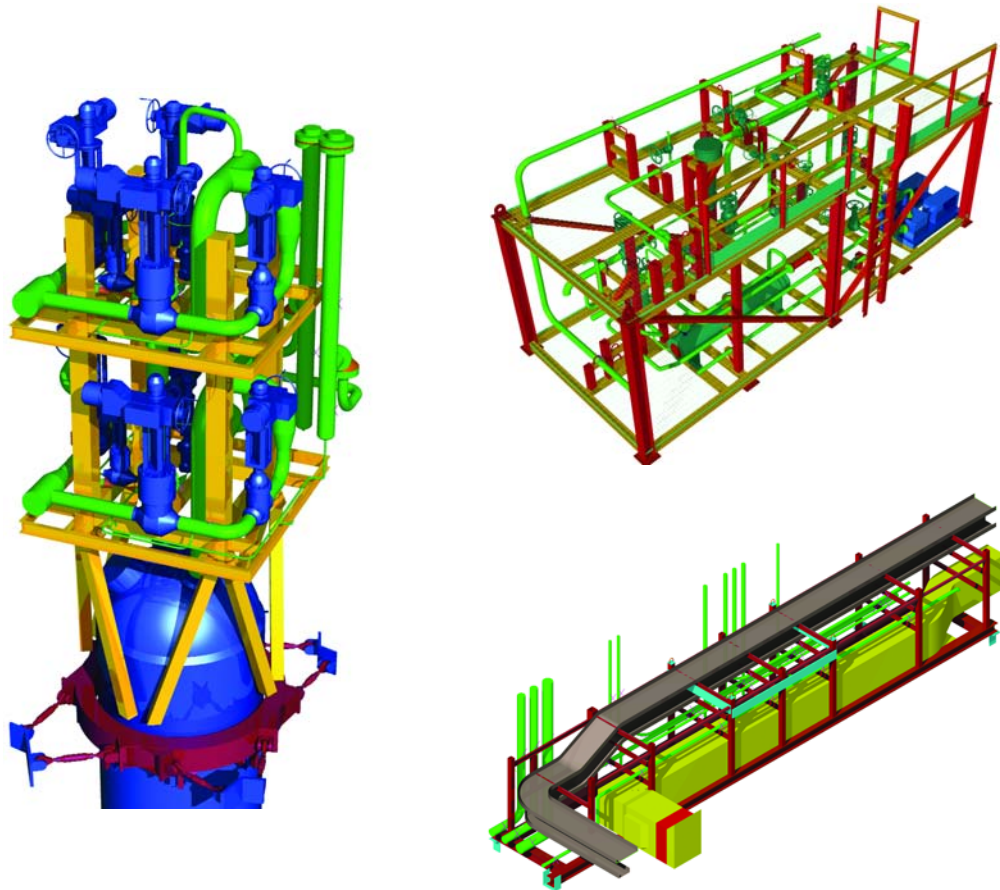
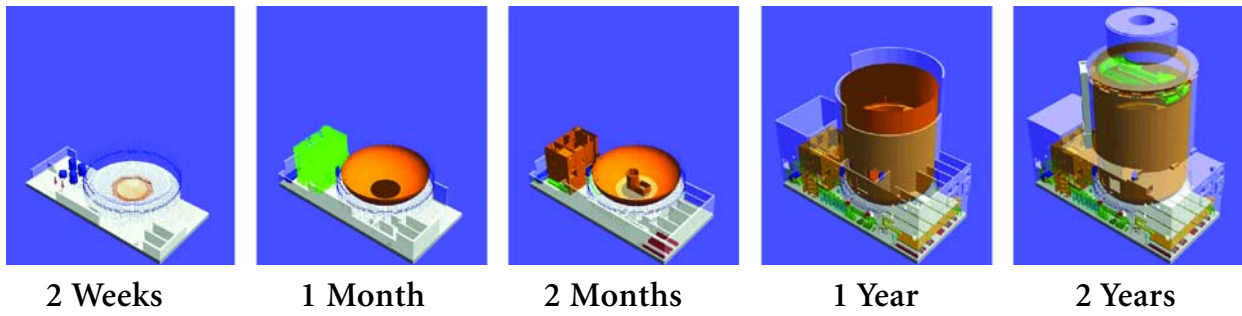

The basic AP1000 module is a rail-shippable unit less than 12 feet high, 12 feet wide and 80 foot long, weighing less than 80 tons. Larger modules could be manufactured for shipment to a site accessible by barge.

## AP1000 Construction Schedule

The standard AP1000 schedule is five years from order placement and three years from first concrete pour to fuel load.

Site Preparation

18 Months

Site Construction

36 Months

Start Up and Testing

6 Months

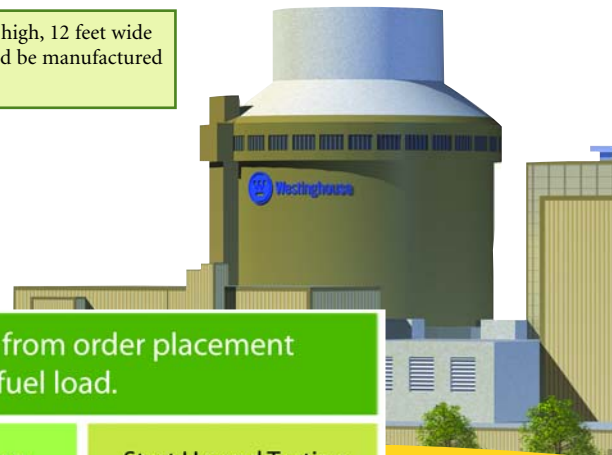

# Improved and more efficient operations

*Nuclear power remains a competitive part of our energy policies because of improved industry performance. Greater nuclear plant performance means more electricity for less money. The AP1000™ pressurized water reactor has several design features that improve worker safety and production, as well as availability and capacity factors.*

## Improved Plant Performance

- 18-month fuel cycle for improved availability and reduced overall fuel cost
- Significantly reduced maintenance, testing and inspection requirements and staffing
- Reduced radiation exposure, less plant waste
- 93 percent availability
- Sixty-year design lifetime



## Operations & Maintenance

An important aspect of the AP1000 design philosophy focuses on plant operability and maintainability. The passive safety features use a much smaller number of valves than do the multiple trains of active pump-driven systems, and there are no safety pumps at all; so, there is less in-service testing to perform. In particular, simplified safety systems reduce surveillance requirements, significantly simplifying technical specifications and reducing the likelihood of forced shutdowns. Lower operating and maintenance requirements lead to smaller maintenance staffs.

The variable-speed canned-motor reactor coolant pumps (RCPs) simplify plant startup and shutdown operations because they are capable, for example, of reducing RCP speed during plant cooldown and providing the capability to vary RCP speed to better control shutdown operating-mode transitions. The RCPs operate at constant speed during power operations, simplifying control actions during load shifts.

The digital I&C design significantly reduces required I&C surveillance testing and simplifies trouble-shooting, repair and post-maintenance testing. The plant includes automation of some cooldown operations and improved steam-dump, low-pressure performance. The advanced control room design significantly improves the operator interfaces and plant operations capabilities.

Overall, the selection of proven components has been emphasized to ensure a high degree of reliability and reduced maintenance requirements. Component standardization reduces spare-parts inventories, maintenance, training requirements, and allows shorter maintenance times. Built-in testing capability is provided for critical components.

Plant layout ensures adequate access for inspection and maintenance. Laydown space provides for staging of equipment and personnel, equipment removal paths, and space to accommodate remotely operated service equipment and mobile units. Access platforms and lifting devices are provided at key locations, as are service provisions such as electrical power, demineralized water, breathing and service air, ventilation and lighting, and computer-data-highway connections.

The AP1000 also incorporates radiation exposure reduction principles to keep worker dose as low as reasonably achievable (ALARA). Exposure length, distance, shielding, and source reduction are fundamental criteria that are incorporated into the design with the result of:

- Minimized operational releases
- Worker radiation exposure greatly reduced
- Total radwaste volumes minimized through features such as no boron load follow, ion exchange rather than evaporation, segregation of wastes at the source, minimization of active components, and packaging in high-integrity containers
- Other (non-radioactive) hazardous wastes minimized through such features as a simplified plant (e.g., elimination of many oil lubricated pumps), careful selection of processes (e.g., laboratory and turbine-side chemistry), and segregation of wastes

The AP1000 is designated for rated performance with up to 10 percent of the steam-generator tubes plugged and with a maximum hot-leg temperature of 321.1°C (610°F). The plant is designed to accept a step-load increase or decrease of 10 percent between 25 and 100 percent power without reactor trip or steam-dump system actuation, provided that the rated power level is not exceeded. Further, the AP1000 is designed to accept a 100 percent load rejection from full power to house loads without a reactor trip or operation of the pressurizer or steam generator safety valves.

### AP1000 - Operating and Maintenance (O&M) Costs

Operating nuclear plants in the U.S. are already competitive producers of electricity compared to coal-fired plants. That virtue is enhanced by fuel cost comprising only about 25 percent of the production costs of a nuclear plant. The remaining 75 percent of production cost is the fixed cost of operation and maintenance. That means that nuclear power production is less sensitive to changes in fuel costs than coal-fired plants where fuel costs can be more than 75 percent of the production cost. AP1000's modern design will engender even less expensive production by requiring less manpower for O&M than current plants for many reasons, including:

- 1) Less equipment and less safety-grade equipment to maintain and test
- 2) Improved equipment, such as the primary system canned motor pumps that are maintenance-free and do not need the complex seal-injection systems of typical shaft-seal coolant pumps
- 3) Features for faster head removal for refueling
- 4) Less waste produced
- 5) Improved protection from and fewer opportunities for radiation exposure (ALARA design)
- 6) Online-diagnosing electronics
- 7) A main control room featuring the latest human-interface design, needing only an operator and supervisor for normal operation

An independent study by the Institute of Nuclear Power Operators (INPO) determined that a passive "single, mature Advanced Light Water Reactor" would require about one-third less O&M staff than a currently operating nuclear plant.



**The Nuclear Renaissance Starts Here.™**

# AP1000™

The Nuclear Renaissance Starts Here.™

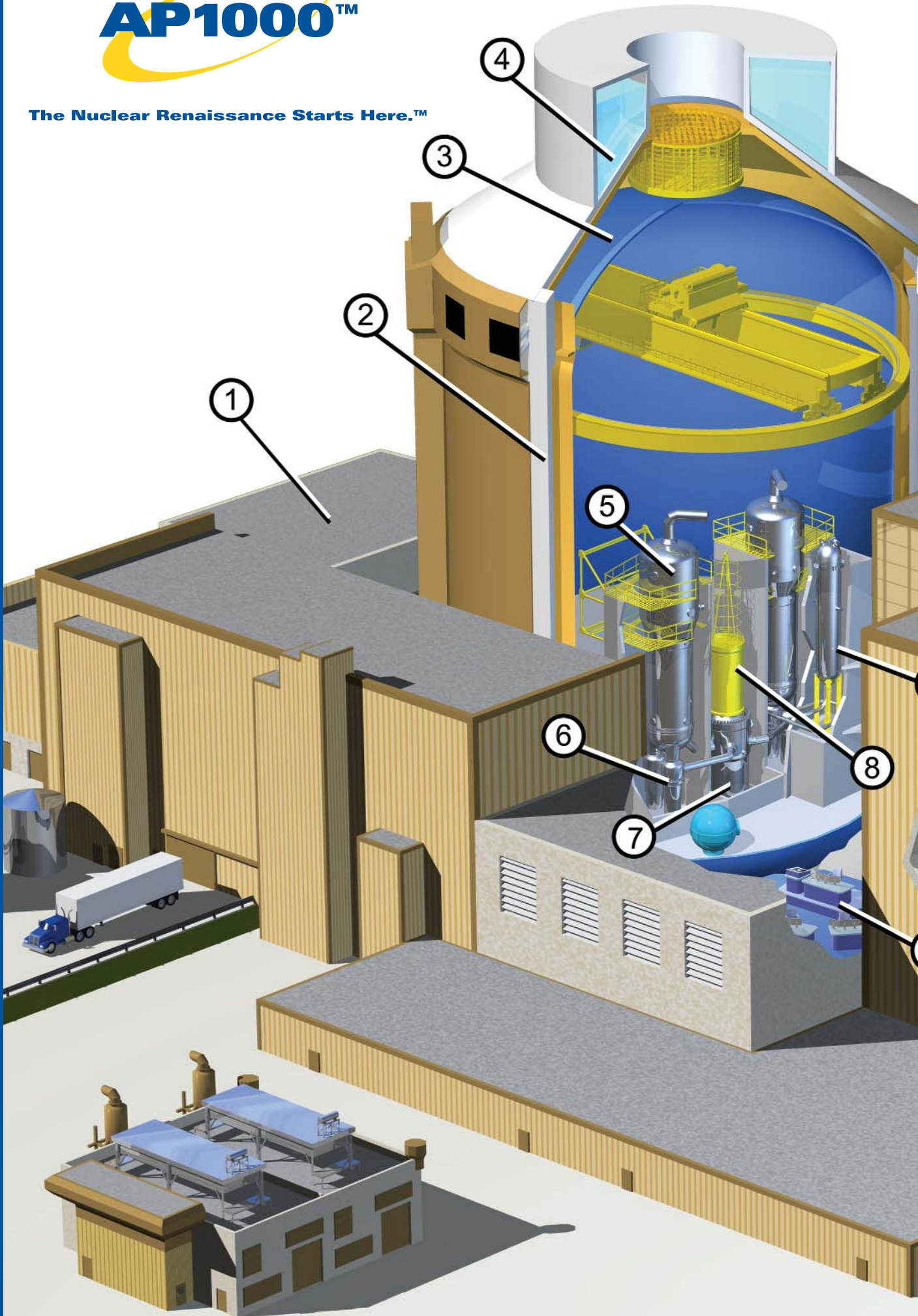

# AP1000

1. Fuel-handling Area
2. Concrete Shield Building
3. Steel Containment
4. Passive Containment Cooling Water Tank
5. Steam Generators (2)
6. Reactor Coolant Pumps (4)

7. Reactor Vessel
8. Integrated Head Package
9. Pressurizer
10. Main Control Room
11. Feedwater Pumps
12. Turbine Generator

This illustration is an artist rendering of the AP1000™ PWR and may not depict actual design and layout.

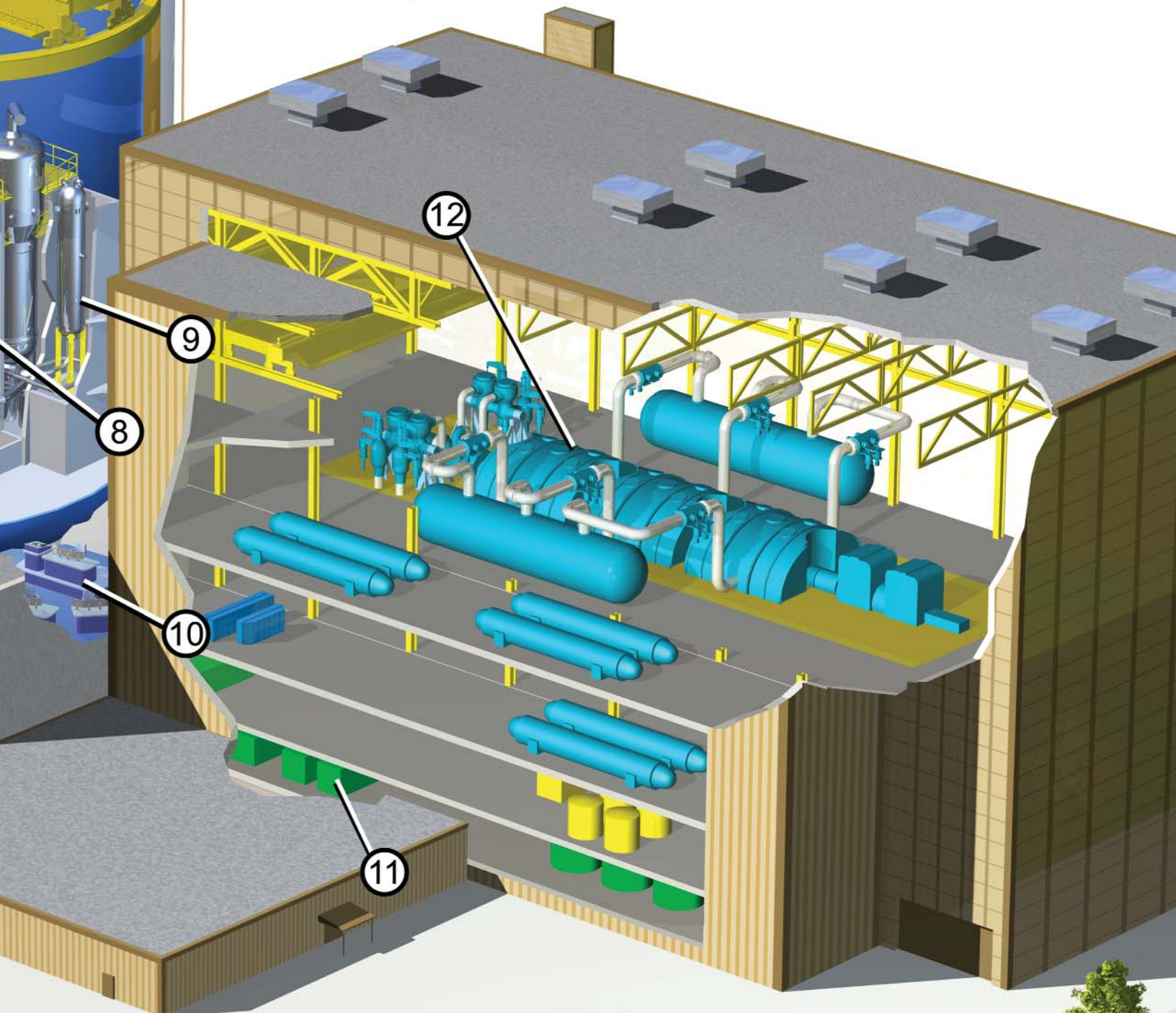



**Westinghouse**

You can be sure...  
if it's Westinghouse

## Availability

The AP1000 power generating system is familiar Westinghouse PWR technology updated from the substantial amount of operating experience accumulated over many decades to enhance plant reliability and operability. The AP1000 steam generators use long-life tube materials and a component design in a size that has recently been used for replacement steam generators. Canned-motor pumps have significantly improved operational reliability in comparison with conventional shaft-seal pumps, and have now attained an experience base in sizes useful for application, again, in PWRs.

The advanced, digital instrumentation and control (I&C) systems feature an integrated control system that avoids reactor trips due to single-channel failure, and provides online diagnostics capabilities. In addition, the plant design provides large margins for plant operation before reaching the safety limits. This assures a stable and reliable plant operation with a goal of reducing the number of unplanned reactor trips to less than one per year. The AP1000 design incorporates design features that are essential to minimizing reactor trips. The design includes optimization of a number of plant variables that provide inputs to the reactor trip signals; increased margin between the normal operating range and the trip setpoint of safety variables; and a number of design features specifically incorporated to minimize unplanned automatic trips. In addition, a Design Reliability Assurance Program helps to focus on the structures, systems and components critical to reactor trip, and to identify new design features and maintenance methods to achieve the plant availability and reliability goals.

Based on the foregoing points, considering the short, refueling outage capability (17 days), and plans to use an 18- or 16-20-month alternating cycle for optimum economics, the AP1000 is expected to exceed the 93 percent availability goal.

The plant has a design life of 60 years based on the service life of the reactor vessel.



**You can be sure ...  
if it's Westinghouse**







**Westinghouse**

[www.AP1000.westinghouse\*\*nuclear\*\*.com](http://www.AP1000.westinghouse<b>nuclear</b>.com)

© 2007 Westinghouse Electric Company LLC. All Rights Reserved  
Designed by Westinghouse Graphic Services and Identity Department